

INSTRUCTION MANUAL

T-318 Thicknesser (240V) 318mm



W800

Table of contents

SECTION	PAGE
I. Technical data	2
II. General safety rules	3
III. Specific safety rules for the thickness planer	5
IV. Electrical information	8
V. Know your thickness planer	10
VI. Assembly and adjustments	11
VII. Operation	13
VIII. Maintenance	18
IX. Replacement parts	22
X. Warranty	24

I. Technical data

MOTOR:	220/240V, 50 Hz, 2000W
SPEED:	9000 RPM (no load)
CUTS PER MINUTE:	18000
MAXIMUM DEPTH OF CUT:	3/32" (3 mm)
MAXIMUM WIDTH OF WOOD:	12 1/2" (317.5 mm)
MAXIMUM THICKNESS OF WOOD:	6" (152 mm)
MINIMUM THICKNESS OF WOOD:	3/16" (5 mm)
WEIGHT:	88 lb (40 kg)

II. General safety rules

Safety is a combination of common sense, staying alert, and knowing how your thickness planer works.

WARNING: TO AVOID MISTAKES THAT COULD CAUSE SERIOUS INJURY, DO NOT PLUG IN THE THICKNESS PLANER UNTIL YOU HAVE READ AND UNDERSTOOD THE FOLLOWING RULES.

1. READ and become familiar with this entire instruction manual. LEARN the tool's applications, limitations, and possible hazards.
2. AVOID DANGEROUS CONDITIONS. DO NOT use power tools in wet or damp areas and DO NOT expose them to rain. Keep work areas well-lit.
3. DO NOT use power tools in the presence of flammable liquids or gases.
4. ALWAYS keep your work area clean, uncluttered, and well-lit. DO NOT work on floor surfaces that are slippery with sawdust or wax.
5. KEEP BYSTANDERS AT A SAFE DISTANCE FROM the work area, especially when the tool is operating. NEVER allow children or pets near the tool.
6. DO NOT FORCE THE TOOL to do a job that it was not designed to do.
7. DRESS FOR SAFETY. DO NOT wear loose clothing, gloves, neckties, or jewellery (rings, watches, etc.) when operating the tool. Inappropriate clothing and items can get caught in moving parts and pull you in. ALWAYS wear non-slip footwear, and tie back long hair.
8. WEAR A FACE MASK OR DUST MASK. Planing operations produce dust.
9. ALWAYS unplug the power cord plug from the electrical outlet when making adjustments, changing parts, cleaning, or working on the tool.
10. KEEP GUARDS IN PLACE AND IN WORKING ORDER.
11. AVOID ACCIDENTAL START-UPS. Make sure the power switch is in the OFF position before plugging in the power cord.
12. REMOVE ADJUSTMENT TOOLS. ALWAYS MAKE SURE all adjustment tools are removed from the saw before turning it on.
13. NEVER LEAVE A RUNNING TOOL UNATTENDED. Turn the power switch to the OFF position. DO NOT leave the tool until it has come to a complete stop.

SAVE THESE SAFETY RULES

II. General safety rules (continued)

14. NEVER STAND ON A TOOL. Serious injury could result if the tool tips or is accidentally jarred. DO NOT store anything above or near the tool.
15. DO NOT OVERREACH. Keep proper footing and balance at all times. Wear oil-resistant, rubber-soled footwear. Keep the floor clear of oil, scraps, and other debris.
16. MAINTAIN TOOLS PROPERLY. ALWAYS keep tools clean and in good working order. Follow instructions for lubricating and changing accessories.
17. CHECK FOR DAMAGED PARTS. Check for alignment of moving parts, jamming, breakage, improper mounting, or any other conditions that may affect the tool's operation. Any part that is damaged should be properly repaired or replaced before use.
18. MAKE THE WORKSHOP CHILDPROOF. Use padlocks and master switches, and ALWAYS remove starter keys.
19. DO NOT operate the tool if you are under the influence of drugs, alcohol, or medication that could affect your ability to use the tool properly.

WARNING: DUST GENERATED FROM CERTAIN MATERIALS CAN BE HAZARDOUS TO YOUR HEALTH. ALWAYS OPERATE THE THICKNESS PLANER IN A WELL-VENTILATED AREA, AND PERFORM PROPER DUST REMOVAL. USE A FACE MASK OR DUST MASK WHEN OPERATING.

WARNING: EXPOSURE TO EXCESSIVE NOISE LEVELS CAN RESULT IN PERMANENT HEARING LOSS. ALWAYS WEAR EAR PROTECTION (SAFETY EAR MUFFS OR EAR PLUGS) TO REDUCE NOISE LEVELS WHEN OPERATING.



ALWAYS WEAR EYE PROTECTION THAT CONFORMS WITH CSA REQUIREMENTS.

FLYING DEBRIS can cause permanent eye damage.

Prescription eyeglasses ARE NOT a replacement for proper eye protection.

SAVE THESE SAFETY RULES

III. Specific safety rules for the thickness planer

WARNING: DO NOT OPERATE THE THICKNESS PLANER UNTIL IT IS COMPLETELY ASSEMBLED AND INSTALLED ACCORDING TO THE INSTRUCTIONS.

WHEN INSTALLING OR MOVING THE THICKNESS PLANER

1. **AVOID INJURY FROM UNEXPECTED PLANER MOVEMENT:**
 - Attach the rubber feet, and bolt or clamp the planer to a firm level surface where there is plenty of room to move the workpiece through the entire cut.
 - Support the planer in a way such that the tables are level and the planer does not rock.
 - Place the thickness planer in a location where operators or bystanders will not stand in line with the wood while planing.
2. **DO NOT STAND ON THE THICKNESS PLANER.** Do not store materials above or near it. Standing on the thickness planer to reach materials could result in serious injury if it tips or is accidentally contacted.

BEFORE OPERATING THE THICKNESS PLANER

1. Read, understand, and follow all operating instructions, safety rules, and symbols in this manual, as well as the warning labels on the tool, before operating, maintaining, and cleaning the thickness planer.
2. Check for proper assembly and proper alignment of moving parts.
3. **INSPECT THE THICKNESS PLANER:**
 - If any part is missing, bent, or broken in any way, or if any electrical part does not work properly, turn the planer OFF and unplug it.
 - Replace damaged or missing parts before using the thickness planer.
 - Make sure the cutter head turns in the right direction. The top should move toward the in-feed table.

SAVE THESE SAFETY RULES

III. Specific safety rules for the thickness planer (continued)

4. TO AVOID INJURY FROM JAMS, SLIPS, OR THROWN PIECES:
 - Use this planer to cut wood only.
 - Plan your hand placement so that your fingers will not be in a place where a sudden slip could cause them to slide or fall into the cutter head. When using only one push block to feed the wood, do not put your other hand on the thickness planer or workpiece.
 - Avoid injury from thrown pieces. Make sure the knives are properly installed and the cutter head knife screws are tight.
 - Adjust the depth of cut to 1/32" (0.8 mm) or less for best results. A deep cut makes feeding the wood harder, and can cause the wood to kickback.
 - Use the right tool. Do not force the thickness planer to do a job that it is not designed to do.
5. INSPECT YOUR WORK AREA:
 - Keep the work area clean and free of clutter or debris. Clear the table of all objects not needed to feed the workpiece.
 - Do not use the planer near flammable liquids, vapours, or gases.
 - Do not perform layout, assembly, or setup work on the planer.
6. PLAN YOUR WORK:
 - Carefully plan your hand placement. Make sure you have proper push blocks, jigs, fixtures, stops, and other items ready to use.
 - Avoid injury from unsafe accessories. Use only recommended accessories.
7. INSPECT THE WORKPIECE. Make sure there are no nails or foreign objects in the area of the workpiece to be planed.
8. PLAN YOUR CUT:
 - Small or thin workpieces can kickback when they tip over on the tables or the cutter head.
 - To avoid contact with the cutter head or workpiece kickback, do not plane workpieces shorter than 6" (152 mm).
 - Do not plane wood thinner than 3/16" (5 mm).
 - Do not cut freehand. Guide the workpiece solidly. Make sure there is no debris between the workpiece and the supports.
 - Use extra caution with large, small, or awkward workpieces.¹
 - Use extra support (tables, sawhorses, blocks) if it is hard to hold the workpiece down to the table. Do not use another person as additional support, or to help feed, support, or pull the workpiece.
 - Do not cut more than one workpiece at a time.

SAVE THESE SAFETY RULES

III. Specific safety rules for the thickness planer (continued)

9. TO AVOID INJURY FROM ACCIDENTAL STARTING OF THE THICKNESS PLANER. Make sure the power switch is in the OFF position before plugging the planer into a power source.

WHEN THE THICKNESS PLANER IS RUNNING

1. KEEP CHILDREN AND BYSTANDERS AWAY FROM THE PLANER.
2. ALLOW THE THICKNESS PLANER TO RUN FOR A WHILE BEFORE CUTTING. If it makes an unfamiliar noise or vibrates, turn the thickness planer OFF immediately, and then unplug it. Do not restart the planer until the problem is identified and corrected.
3. DO NOT FORCE THE TOOL. Feed the workpiece into the thickness planer only fast enough to let the tool cut without bogging down.
4. BEFORE ATTEMPTING TO FREE JAMMED MATERIAL, turn the thickness planer OFF and wait for all moving parts to stop. Unplug the thickness planer.

WARNING: DO NOT MAKE A CARELESS ERROR. A MOMENT OF NEGLIGENCE CAN CAUSE A SEVERE INJURY.

SAVE THESE SAFETY RULES

IV. Electrical information

GROUNDING INSTRUCTIONS

IN THE EVENT OF A MALFUNCTION OR BREAKDOWN, grounding provides the path of least resistance for an electric current and reduces the risk of electric shock. This tool is equipped with an electrical cord that has an equipment grounding conductor and a grounding plug. The plug **MUST** be plugged into a matching outlet that is properly installed and grounded in accordance with ALL local codes and ordinances.

DO NOT MODIFY THE PLUG PROVIDED. If it will not fit in the outlet, have the proper type of outlet installed by a licenced electrician.

IMPROPER CONNECTION of the equipment grounding conductor can result in an electric shock. The conductor with the green insulation (with or without yellow stripes) is the equipment grounding conductor. If repair or replacement of the electrical cord or plug is necessary, **DO NOT** connect the equipment grounding conductor to a live terminal.

CHECK with a licenced electrician or service person if you do not completely understand the grounding instructions, or if you are not sure whether the tool is properly grounded.

USE ONLY THREE-WIRE EXTENSION CORDS that have 3-pronged plugs and 3-pronged outlets that accept the tool's plug, as shown in **Fig. A**. Repair or replace a damaged or worn cord immediately.

Fig. A

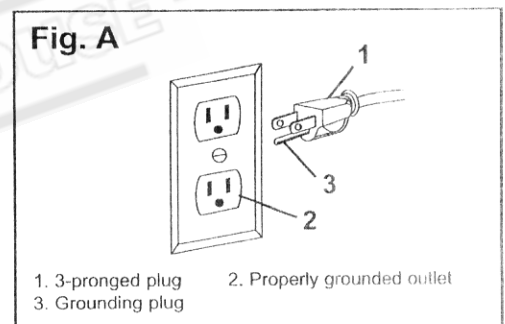

CAUTION: IN ALL CASES, VERIFY THE OUTLET IN QUESTION IS PROPERLY GROUNDED. IF YOU ARE NOT SURE, HAVE A LICENCED ELECTRICIAN CHECK THE OUTLET.

SAVE THESE SAFETY RULES

IV. Electrical information (continued)

GUIDELINES FOR USING EXTENSION CORDS

WARNING: THIS THICKNESS PLANER IS INTENDED FOR INDOOR USE ONLY. DO NOT EXPOSE TO RAIN OR USE IN DAMP LOCATIONS.

Make sure your extension cord is in good condition. When using an extension cord, be sure to use one that is heavy enough to carry the current that your product will draw. An undersized cord will cause a drop in line voltage, which will result in loss of power and overheating. The table below shows the correct size to be used according to cord length and nameplate ampere rating. If in doubt, use the next heavier gauge. The smaller the gauge number, the heavier the cord.

Minimum Gauge for Extension Cords (AWG)

Ampere Rating		Total Length of Cord in Feet (metres)			
More Than	Not More Than	25' (7.6 m)	50' (15 m)	100' (30.4 m)	150' (45.7 m)
0	6	18	16	16	14
6	10	18	16	14	12
10	12	16	16	14	12
12	16	14	12	Not Recommended	

Be sure your extension cord is properly wired and in good condition. Always replace a damaged extension cord, or have it repaired by a qualified person before using it. Protect your extension cords from sharp objects, excessive heat, and damp or wet areas.

Use a separate electrical circuit for your tools. This circuit must consist of not be less than #12 wire, and should be protected with a 15 A time-delayed fuse. Before connecting the motor to the power line, make sure the switch is in the OFF position and the electric current is rated the same as the current stamped on the motor nameplate. Running at a lower voltage will damage the motor.

WARNING: THIS TOOL MUST BE GROUNDED WHILE IN USE IN ORDER TO PROTECT THE OPERATOR FROM ELECTRIC SHOCK.

SAVE THESE SAFETY RULES

V. Know your thickness planer

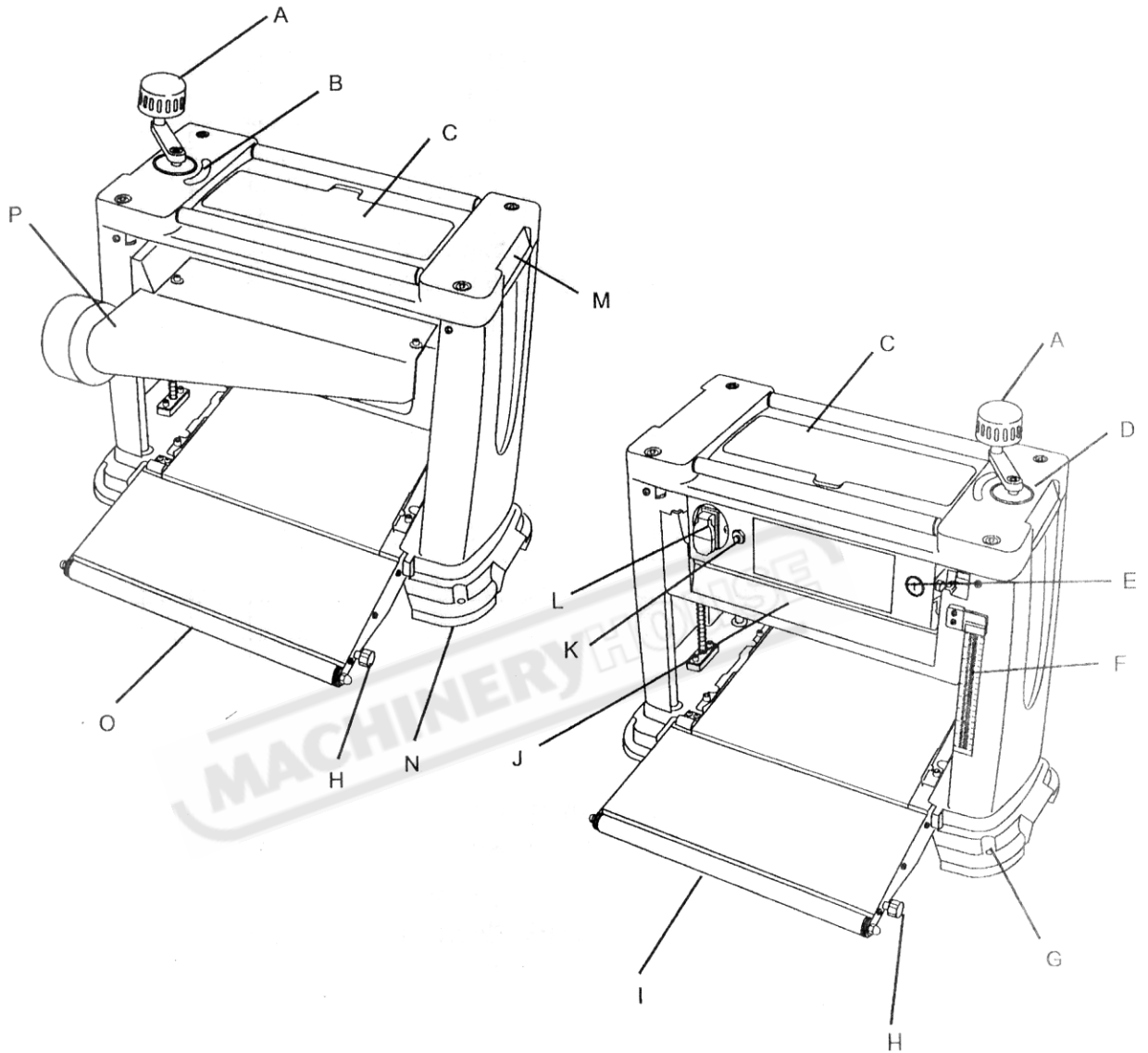

- | | | | |
|---|---|---|-------------------------|
| A | Cutter head depth adjustment handle | I | Support/in-feed roller |
| B | Up/Down direction decal | J | Cutter head assembly |
| C | Storage compartment | K | Reset button |
| D | Cutter head depth scale | L | ON/OFF switch |
| E | Motor brushes | M | Carrying handle |
| F | Measurement scale | N | Rubber feet |
| G | Mounting holes | O | Support/out-feed roller |
| H | In-feed/out-feed roller extension knobs | P | Dust chute |

VI. Assembly and adjustments

Unpacking (Fig. 1)

Carefully unpack the thickness planer and all of its parts, and compare them against the list below. Do not discard the carton or any packaging until the thickness planer is completely assembled.

WARNING: IF ANY PART IS MISSING OR DAMAGED, DO NOT PLUG THE THICKNESS PLANER IN UNTIL THE MISSING OR DAMAGED PART IS REPLACED AND ASSEMBLY IS COMPLETE.

Fig. 1

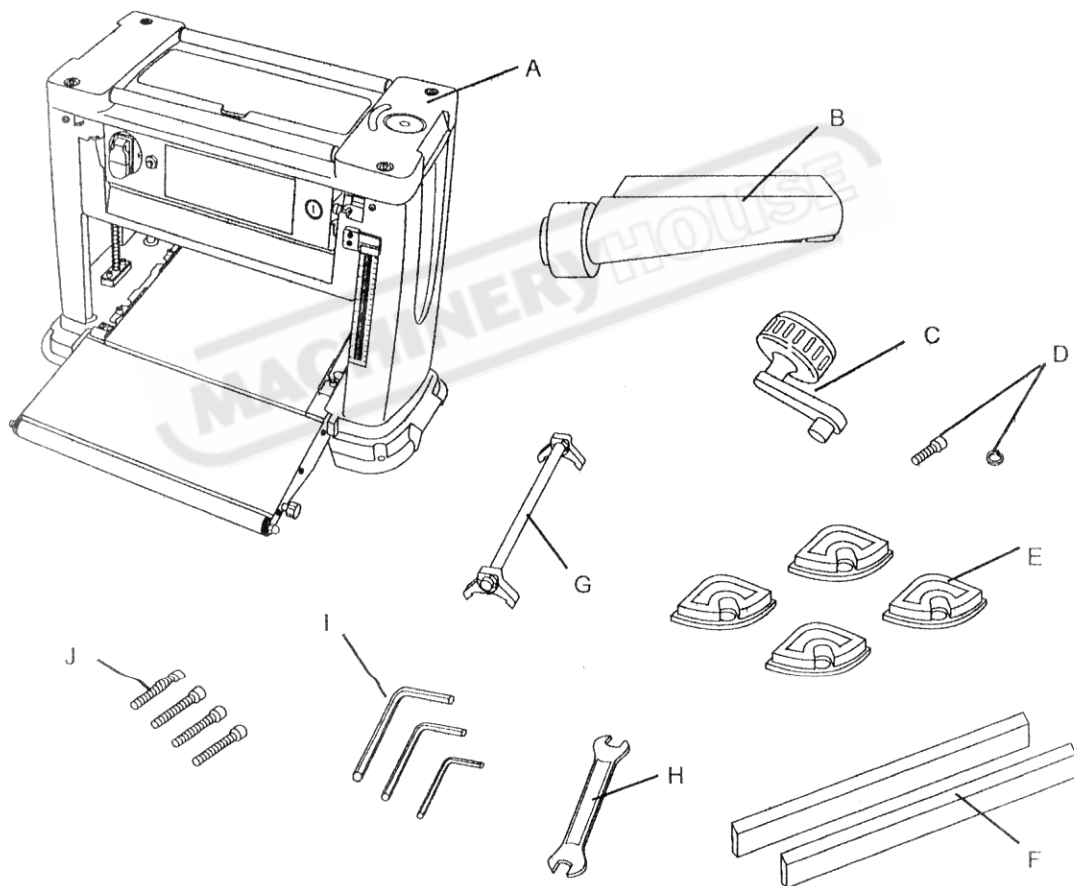

- | | | | |
|---|--|---|----------------------------|
| A | Planer | F | Spare set of blades |
| B | Dust chute | G | Knife depth/alignment tool |
| C | Cutter head depth adjustment handle | H | Knife alignment wrench |
| D | Hex screw and washer for cutter head depth adjustment handle | I | Hex keys (3) |
| E | Rubber feet (4) | J | Mounting bolts (4) |

VI. Assembly and adjustments (continued)

ASSEMBLY

Install the rubber feet and mount the thickness planer (Fig. 2)

Before operating the thickness planer, install the four rubber feet and mount the thickness planer firmly to a workbench or other rigid frame.

1. Lift up the planer and place a rubber foot (1) in position, aligning the hole in the foot with the mounting hole on the planer.
2. Push each rubber foot onto the planer.
3. Place the planer on a workbench or rigid frame.
4. Place a mounting bolt through the hole (2) at each corner of the thickness planer, and secure it to the workbench or frame using quality hardware.

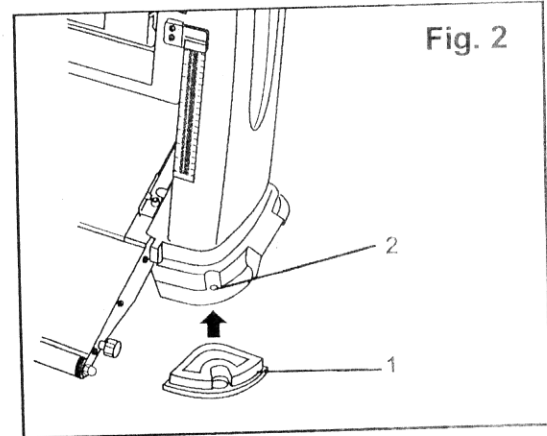

Fig. 2

Install the cutter head handle (Fig. 3)

1. Place the cutter head handle (1) over the spindle on the top of the thickness planer.
2. Secure the handle using the hex screw and washer (2) provided.

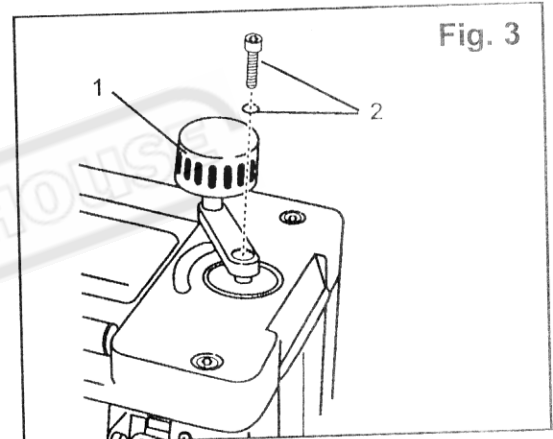

Fig. 3

Install the dust chute (Fig. 4)

1. Loosen the 3 bolts (1) at the rear of the cutter head assembly, and move the washers away from the surface so that they are next to the head of the bolt.
2. Remove the 2 bolts and washers (2) from the top of the cutter head assembly.
3. Align the 3 notches on the dust chute (3) over the 3 bolts (1) at the rear of the cutter head assembly.
4. Align the 2 holes on the top of the dust chute over the 2 holes on the top of the cutter head assembly.
5. Tighten the 3 bolts (2) that secure the dust chute to the rear of the cutter head assembly.
6. Replace and tighten the 2 bolts and washers (2), that secure the top of the dust chute to the cutter head assembly.

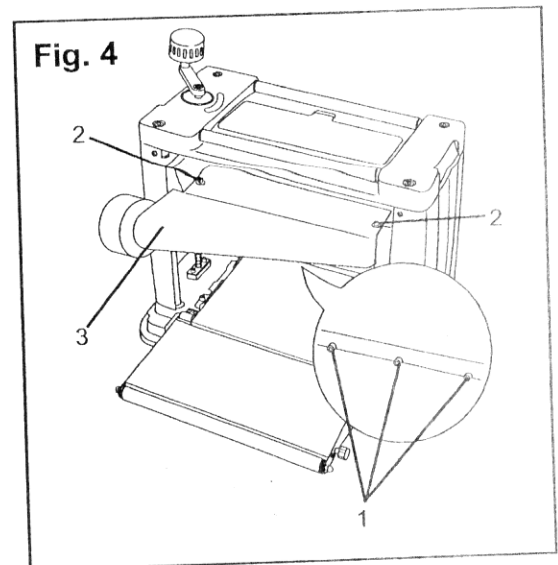

Fig. 4

VII. Operation

WARNING: IF YOU HAVE TO REMOVE A WORKPIECE FROM THE THICKNESS PLANER, MAKE SURE THE ON/OFF SWITCH IS IN THE OFF POSITION AND THE POWER CORD IS REMOVED FROM THE POWER SOURCE.

ON/OFF Switch (Fig. 5)

1. To turn the thickness planer ON, insert the safety key (1) into the slot. Move the switch to the ON (up) position.
2. To turn the planer OFF, move the switch to the OFF (down) position.
3. To lock the switch in the OFF position, grasp the safety key (1) and pull it out of the switch.

Reset Button (Fig. 5)

In the event of an overload, the thickness planer is equipped with an overload circuit.

If the planer experiences an overload:

1. Turn the ON/OFF switch to the OFF position.
2. Unplug the power cord from the power source.
3. Remove the workpiece, if present.
4. Plug the power cord back into the power source.
5. Press the reset button (2).
6. Turn the ON/OFF switch to the ON position.

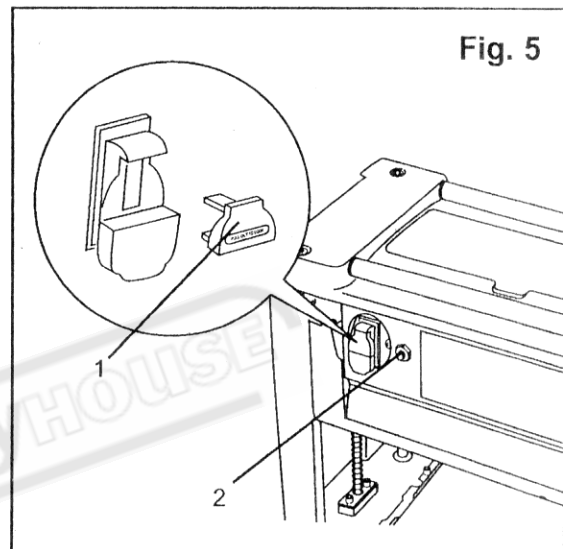

VII. Operation (continued)

Getting started

Before you start, check for loose fasteners or hardware. Make sure the cutter head knife guard is securely mounted and the cutter head rotates freely.

With the power switch in the OFF position, lower the cutter head to about 1" (25.4 mm) to the table. Turn the power switch to the ON position. Allow the planer to reach full speed. Watch and listen for excessive vibration.

If any excessive vibration is detected, turn the thickness planer OFF and unplug it from the power source. Check for any loose parts. Tighten or make adjustments if necessary. Do not operate the thickness planer until it is running smoothly.

Planing specifications

Plane select lumber or wood that has a minimum number of tight knots. Wood with many knots or loose knots has a tendency to cause premature cutter head knife wear, and increases the risk of unsafe operation.

Do not plane lumber or wood that is contaminated with metal, paint, dirt, water, or moisture from tree sap, or wood that is severely bowed, warped, or twisted.

Practice on a scrap piece first in order to become familiar with the type of wood you are planing. Take into consideration the hardness, grain pattern, dryness, and straightness of the lumber or wood.

Stock	Minimum	Maximum
Thickness	3/16" (5 mm)	6" (152 mm)
Width	3/4" (19 mm)	12 1/2" (317.5 mm)
Length	8" (20.3 cm)	unlimited
Depth of cut	–	3/32" (3 mm)

VII. Operation (continued)

Planing operation

The thickness planer will automatically feed the workpiece into and out of the cutter head. Do not force the planer to work faster than it is designed to work. Damage to the workpiece and the planer can result.

Thickness planers work best if at least one side of the workpiece is flat. If both sides are rough, the planer should be used to create one flat side. Plane the opposite side after one side is flat and smooth.

Planing should be carried out in steps in order to achieve the final planing thickness. If the thickness is to be reduced by 1/4" (6.4 mm), 1/8" (3.2 mm) should be removed from each side. This will also allow the planed workpiece to dry and cure uniformly.

Measure the thickest part of the workpiece that is being planed. Make light cuts on both sides.

Do not attempt to make a deep cut, or a cut that is deeper than 1/32" (0.8 mm). Make several passes until the desired thickness is achieved. Light cuts create a finer finish.

Avoid snipe or depressions made by the cutter head knives at the beginning or the end of the board, by supporting both ends evenly. Keep the board level during the entire planing operation.

VII. Operation (continued)

Feeding the workpiece (Fig. 6 and 7)

Always feed the workpiece with the grain (1), if possible. If the workpiece must be fed against the grain (2), make very light cuts.

Hold the workpiece down firmly along the workpiece guides and allow the planer to automatically feed the workpiece to the cutter head.

Note: The planer will automatically feed the workpiece into and out of the cutter head. Do not force the workpiece into the planer or make the planer work faster than it is designed to work. Damage to the workpiece and the planer can result.

Fig. 6

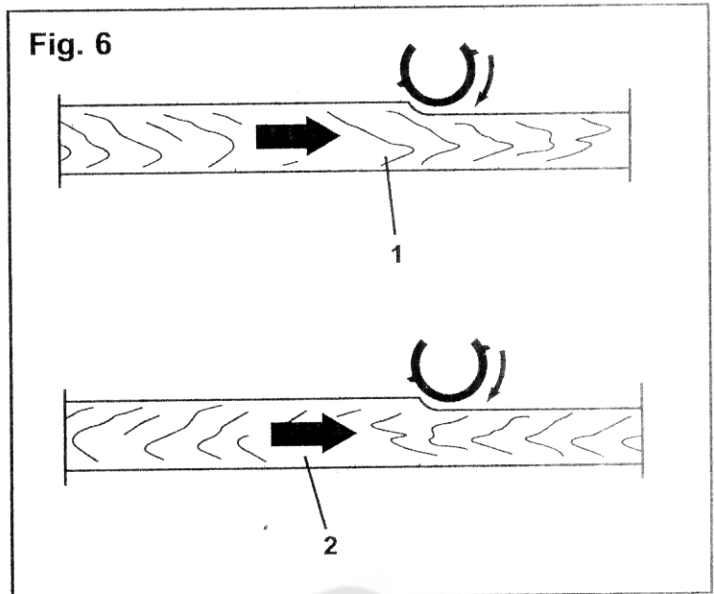

Workpiece support (Fig. 7)

Prevent sagging or snipe in the workpiece during planing. Make sure the workpiece is supported along its entire length. If necessary, extend the length of the in-feed and out-feed tables in order to support the workpiece.

1. Loosen the in-feed/out-feed roller extension knobs (3).
2. Pull the in-feed/out-feed extension rollers (4) out to the desired length.
3. Tighten the knobs (3) to secure the in-feed/out-feed table extensions.

Note: If additional support is needed for the workpiece, place supports on both ends of the planer, or install the planer at a depth where the planing surface is level with the workbench. The supports must be at the same height as the planer in-feed/out-feed tables, or the depth of installation must be such that the workbench is at the same height as the planer.

Fig. 7

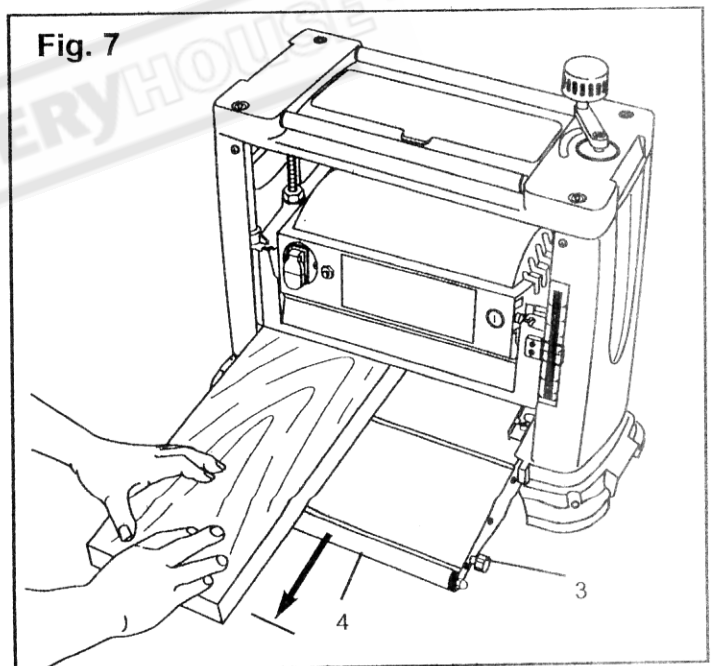

VII. Operation (continued)

Setting the planing depth (Fig. 8 – 10)

Establish the starting point before attempting to plane the surface. The depth of the cutter head contact with the workpiece should only be enough to brush the surface. DO NOT set the cutter head too deep.

Measure the workpiece at its thickest point. Use the measurement scale **(1)** at the feed side of the planer to approximate the starting point of the first pass. Your first attempt at planing is intended to brush the surface.

It is good practice to measure the workpiece after every planing operation.

1. Turn the power switch **(2)** to the ON position.
2. Slowly guide the workpiece along the workpiece guides into the planer. If the cutter head makes contact with the workpiece, back the workpiece out and raise the cutter head using the cutter head depth adjustment handle **(3)**.
3. Repeat the step of slowly guiding the workpiece along the guides into the planer, rotating the cutter head adjustment handle in increments of 1/8 of a turn or less in order to lower the cutter head until it just brushes the surface of the workpiece. This will establish the starting point for the next pass.
4. Use the cutter head depth adjustment scale **(4)** to determine the desired amount to plane. The planer will automatically feed the workpiece into and out of the cutter head. Do not force the planer to work faster than it is designed to work. Damage to the workpiece and the planer can result.

Remember, planing should be done in steps in order to achieve the final planing thickness. If the thickness is to be reduced by 1/4" (6.4 mm), 1/8" (3.2 mm) should be removed from each side. Measure the workpiece after every planing operation.

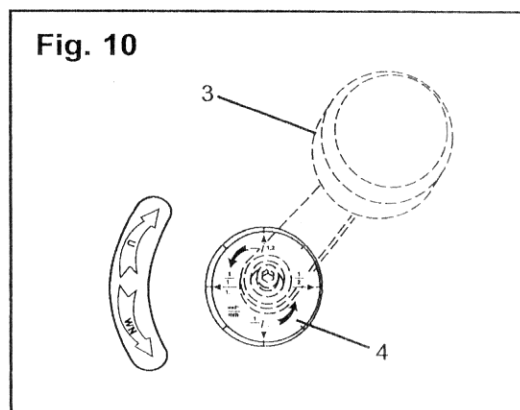
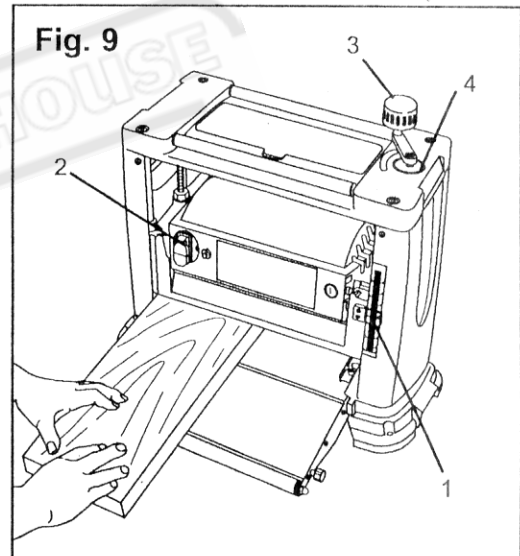
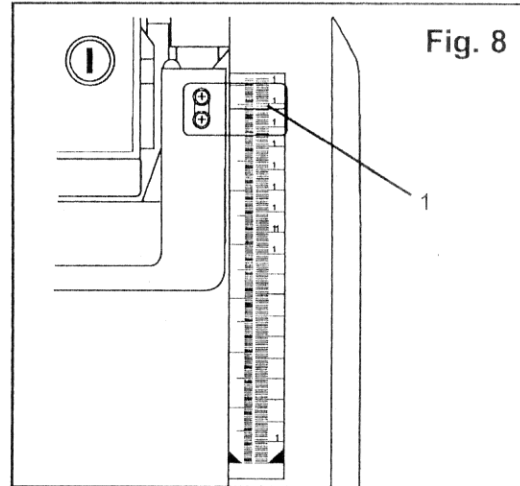

VIII. Maintenance

Replacing cutter head knives and cleaning

WARNING: TURN THE POWER SWITCH TO THE OFF POSITION AND UNPLUG THE POWER CORD FROM THE POWER SOURCE BEFORE ADJUSTING, MAINTAINING, CLEANING, OR LUBRICATING THE THICKNESS PLANER. USE CARE WHEN HANDLING THE KNIVES. THE CUTTING EDGE CAN BE VERY SHARP.

Change one knife at a time. Take note of the orientation of the knife and the knife anchor. Make sure the springs below the knife stay in place when you remove and install the knife.

Inspect the feed rollers after every use. Resin and tar will build up. Use a non-flammable tar and pitch remover solvent to clean the rollers.

Cutter head guard (Figs. 11 and 12)

1. Turn the thickness planer OFF and unplug it.
2. Rotate the cutter head depth adjustment handle (1) to raise cutter head to the highest position.
3. Remove the cutter head depth adjustment handle (1).
4. Remove the 4 cover screws (2) using the hex key supplied.
5. Remove the cover (3).
6. Remove the 2 hex bolts and washers (4) that secure the dust chute (5).
7. Use a clean dry rag to wipe away any build-up of debris from underneath cover and the guard. Use penetrating oil to clean all moving parts and the depth adjustment screws. Apply a light coat of medium weight oil after clean-up. Apply a light coat of paste wax to the table and in-feed and out-feed surfaces. Do not use too much wax; it can hinder the planing and staining of your workpiece.

Knife removal (Fig. 12 and 13)

1. Rotate the cutter head at the pulley (6) so that one knife is facing up.
2. Loosen the knife anchor screws (7) by turning the screws in a clockwise direction (8).
3. Carefully remove the knife.

Fig. 11

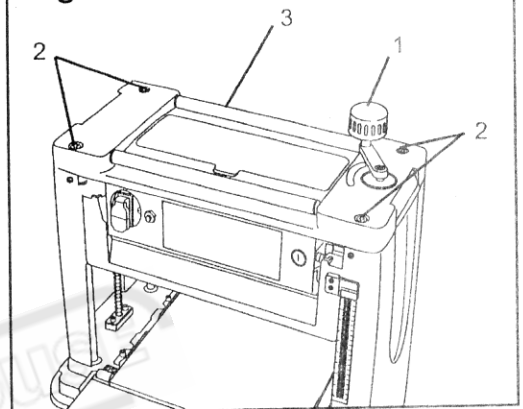

Fig. 12

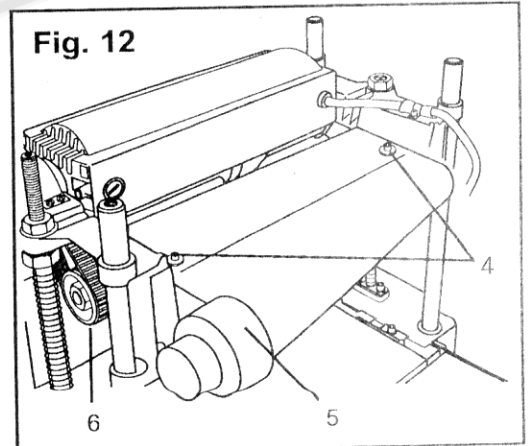
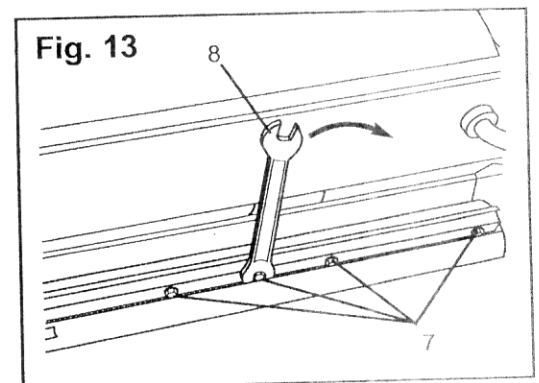

Fig. 13



VIII. Maintenance (continued)

WARNING: TURN THE POWER SWITCH TO THE OFF POSITION AND UNPLUG THE POWER CORD FROM THE POWER SOURCE BEFORE ADJUSTING, MAINTAINING, CLEANING, OR LUBRICATING THE PLANER. USE CARE WHEN HANDLING THE KNIVES. THE CUTTING EDGE CAN BE VERY SHARP.

Knife installation (Fig. 14 and 15)

1. Clean knives regularly. Gum and pitch collects on knives, and causes excess friction during operation. Knives will overheat and wear. Remove knives to clean. Use a gum and pitch remover.
2. Carefully place the knife (1) back in the cutter head (2). Make sure the springs (3) are in place. The knife must be installed as shown in Fig. 14.
3. Place the knife depth/alignment tool (4) on the cutter head, as shown in Fig. 14, with the lobe (5) making contact with the edge of the knife.

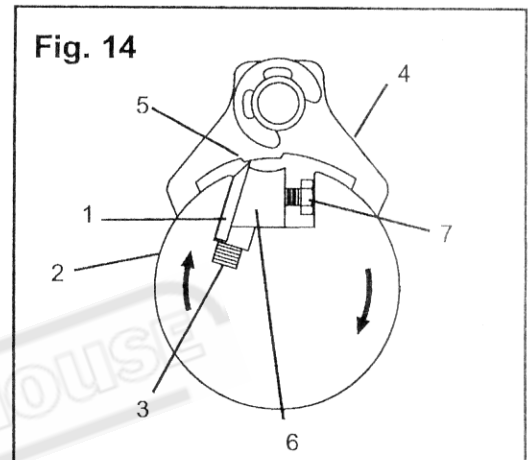

4. Apply light pressure to the knife depth/alignment tool (4) and make sure the knife and knife anchor (6) are centred in the cutter head.

Note: The knives and the knife anchors must be centred in the cutter head. If the knives and anchors are not centred in the cutter head, they will rub against the cutter head carrier and planer damage will result.

5. While applying light pressure to the knife depth/alignment tool (4), tighten the anchor screws (7) by turning in a counter-clockwise direction (8) alternately from one side to the other, starting from the outside and working toward the inside. Repeat these steps for the second knife.
6. Reinstall the guard and the cover. Use care when installing the planer cover, and make sure the measurement scale is outside of the cover.
7. Clean the exterior of the planer with a clean dry rag. Apply a light coat of paste wax in order to ease cleaning and reduce dust build-up.

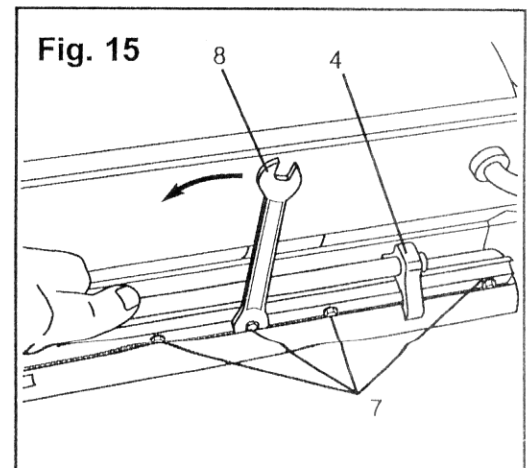

VIII. Maintenance (continued)

Sharpening cutter head knives (Fig. 16)

The knives can be honed individually using an ordinary oilstone (1). Make sure the oilstone is not worn in the centre, it must be flat. Be sure to remove any burrs on the flat side. If the blades are nicked, they must be replaced or reground. Blades can be reground several times until they become 9/16" (14 mm) wide. Have your blades reground by an experienced person.

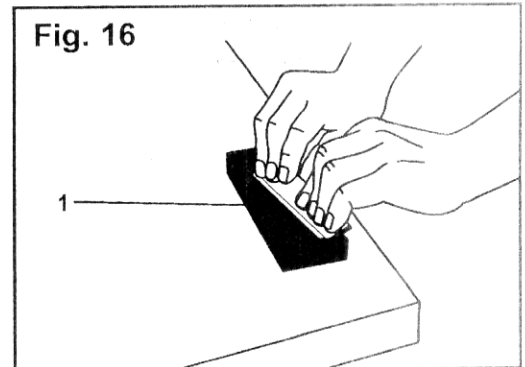

WARNING: BE SURE TO UNPLUG THE POWER CORD FROM THE POWER SOURCE BEFORE INSPECTING THE CARBON BRUSHES.

Carbon brush replacement (Fig. 17)

Check the condition of the carbon brushes after 50 hours of use. If the brushes are worn to 1/16" (2 mm) in length, replace them.

To inspect the carbon brushes:

1. Loosen and remove the two brush caps (1) (front and rear) using a slotted screwdriver.
2. Carefully remove the caps from the motor. The caps are spring-loaded from the spring on the brush. Take note of their position inside the motor.
3. Pull out the brush. Inspect the brush (2) and replace it if necessary. Be sure to replace both brushes at the same time even if only one is damaged.

Note: After inspecting the brushes, be sure to install the brushes into the same position that they were removed from if you are not installing new ones.

4. Position the brushes inside the motor. Tighten the brush caps snugly. Do not overtighten.

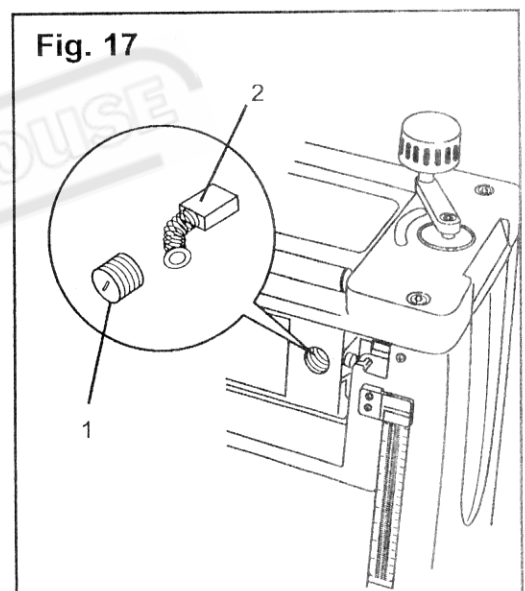

VIII. Maintenance (continued)

Storing (Fig. 18 and 19)

Store the planer in a cool dry place. Clean and lubricate prior to storage.

Apply a light coat of oil to the knives in order to protect them from moisture. Be sure to clean the knives after storing.

Place the knife depth alignment tool and the wrenches inside the storage compartment **(1)** in the cover.

Fold up the power cord **(2)** and place it on top of the cutter head assembly at the rear of the thickness planer.

Fold the in-feed and out-feed rollers up when the planer is not in use.

Fig. 18

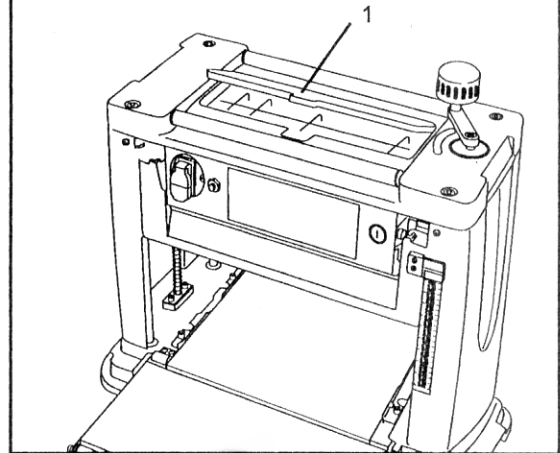
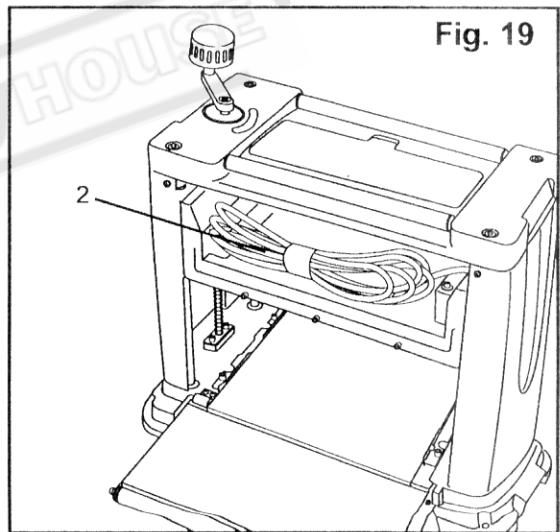

Fig. 19



IX. Replacement parts

No.	Description	Qty	No.	Description	Qty	No.	Description	Qty
1	Nut, M6	4	52	Retainer 40	1	103	Screw, M5x10	2
2	Thread rod 6x25	4	53	Key, 5x11	1	104	Motor housing	1
3	Flat washer 6	8	54	Driven wheel	1	105	Stator	1
4	Spring pin, 3x18	4	55	Nut, M16x1.5	1	106	Baffle plate	1
5	Jointer	4	56	Belt	1	107	Bearing 6200-2Z	1
6	Nut, M6	8	57	Dust chute	1	108	Screw, M5x60	2
7	Screw, M6x20	4	58	Screw ST6x20	2	109	Armature	1
8	Stopper (B)	4	59	Body	1	110	Bearing 6200-2Z	1
9	Extension bar	4	60	C-cover	1	111	Gear box cover	1
10	Roll pole	2	61	Indicator	1	112	Bearing (C)	2
11	Shaft	2	62	Screw, M4x10	4	113	Gear (B)	1
12	Extension table	2	63	Flat washer 4	17	114	Switch	1
13	Spring pin, 3x16	4	64	Sprocket wheel	1	115	Shaft (A)	1
14	Nut, M5	8	65	Motor assembly	1	116	Power cord	1
15	Flat washer, 5	41	66	Stop pin	2	117	Cord bushing	1
16	Bar holder	4	67	Sprocket gear	4	118	Strain relief	1
17	Hex bolt, M5x16	8	68	Washer	3	119	Screw, ST4.2x12	4
18	Screw, M4x8	12	69	Spring washer 6	6	120	Shaft (B)	1
19	Link block	2	70	Screw, M6x16	3	121	Key, 3x7	1
20	Pin, Φ 2.5x12	4	71	Crank handle assembly	1	122	Gear (C)	1
21	Rubber feet	4	72	Top guard (B)	1	123	Bearing (D)	2
22	Screw, M8x20	8	73	Rotation mark	1	124	Sleeve	2
23	Hex bolt, M6x25	4	74	Screw M4x20	2	125	Wave washer 4	3
24	Spring washer 8	4	75	Tool box	1	126	Screw, ST5x60	1
25	Cable clip	1	76	Tool box cover	1	127	Screw, ST5x50	3
26	Flat washer 8	4	77	Screw, M4x8	6	128	Shaft	1
27	Retainer 10	4	78	Top guard (A)	1	129	Key, 4x10	1
28	Cone gear	4	79	Chain	2	130	Bearing	1
29	Column	4	80	Side cover	1	131	Motor label	1
30	Guide plate	2	81	Nut M4	2	132	Carbon brush	2
31	Spacer	2	82	Bushing (A)	3	133	Brush cap	2
32	Threaded pole (A)	1	83	Bushing (B)	1	134	Retainer 16	1
33	Key, 4x8	4	84	Retainer 37	1	135	Gear (A)	1
34	Block	2	85	Spring (A)	1	136	Bearing	1
35	Base	1	86	Bearing 6202-2RZ	1	137	Gear box	1
36	Side cover	2	87	Spring (B)	3	138	Sponge pad	1
37	Scale	1	88	Bearing (A)	4	139	Dust guard	1
38	Rivet 6x25	4	89	Bearing clamp	4	140	Current protector	1
39	Screw M6x20	3	90	Screw, M5x10	4	141	Plug	4
40	Spring washer 5	18	91	Compression spring (B)	1	142	Screw, ST3x8	2
41	Screw, M5x12	29	92	Roller guide	2	143	Cover	1
42	Knob	2	93	Blade shaft	1	144	Nut, M12	1
43	Spring block	4	94	Thread sleeve (LH)	1	145	Block	1
44	Thread sleeve	1	95	Thread pole (B)	1	146	Screw, M4x12	1
45	Adjustment nut	2	96	Transport rod	1	147	Spring washer 4	1
46	Spacer	4	97	Bearing (B)	2			
47	Work table	1	98	Anti-dust cover	1	999	Instruction manual (not shown)	1
48	Blade	2	99	Screw, M5x8	6			
49	Blade clamp	2	100	Link block (RH)	2			
50	Screw	14	101	Compression spring (A)	1			
51	Bearing 6203-2RZ	1	102	Brush holder	2			

IX. Replacement parts (continued)

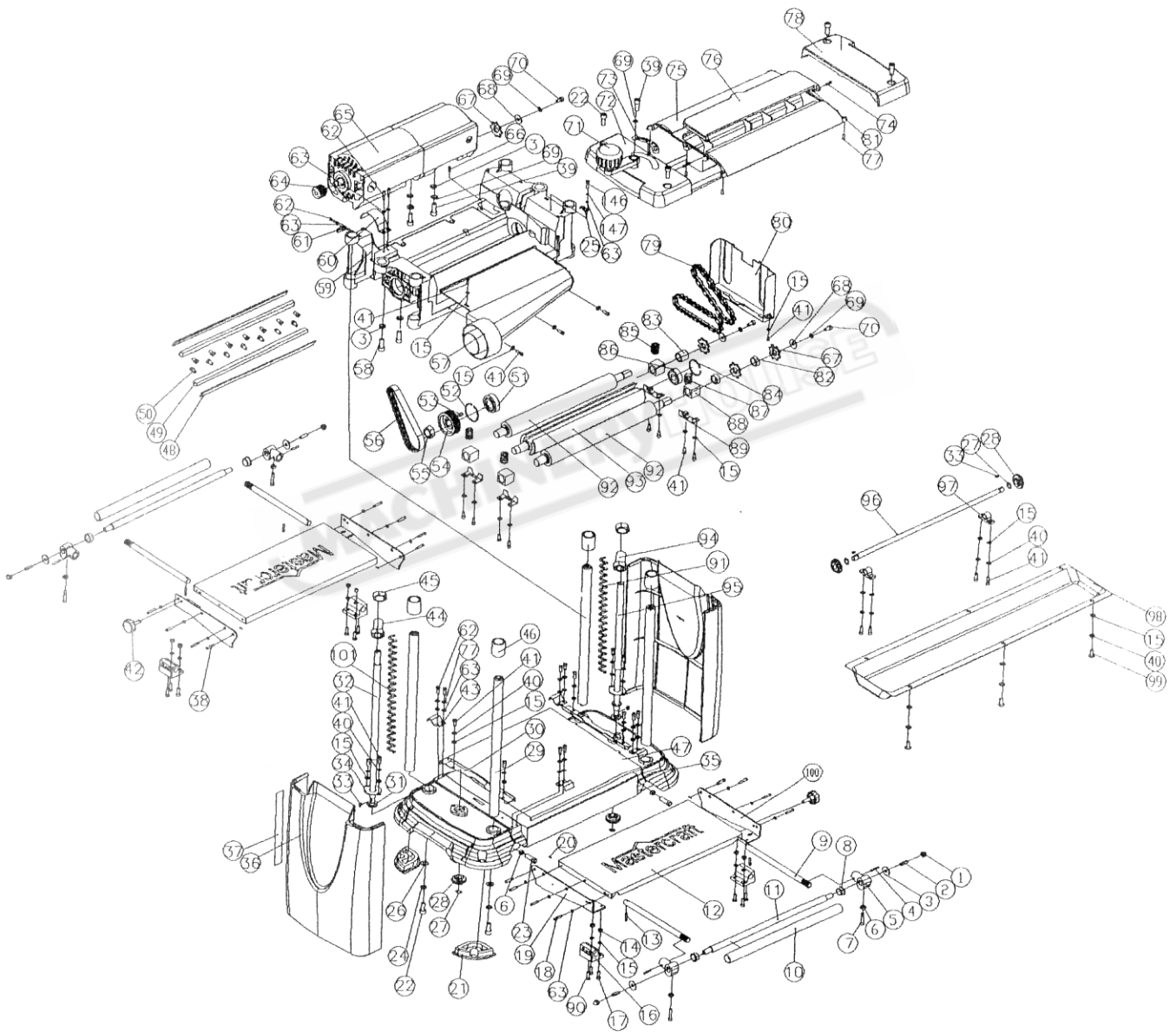

IX. Replacement parts (continued)

Motor Assembly

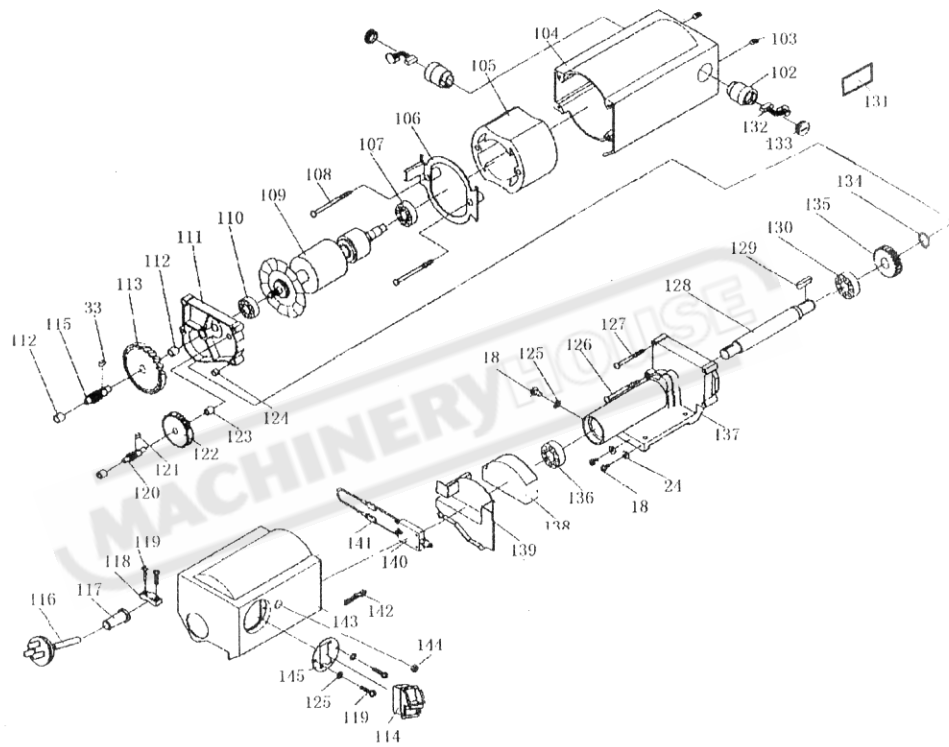

PLANT SAFETY PROGRAMME

NEW MACHINERY HAZARD IDENTIFICATION, ASSESSMENT & CONTROL

Stock Code: W800 Description: Thicknesser Model: T-318 Brand: HAFCO

Developed in Co-operation Between A.W.I.S.A and Australia Chamber of Manufactures
This program is based upon the Australian Worksafe Standard for Plant(NOHSC:1010-1994)

Item No.	Hazard Identification	Hazard Assessment	Risk Control Strategies <small>(Recommended for Purchase / Buyer / User)</small>
A	ENTANGLEMENT	HIGH	Eliminate, avoid loose clothing / Long hair etc.
B	CRUSHING	LOW	Heavier timber must be supported Be sure that when rising and falling planner tables hands are well away from locating, clamping and pivoting area.
C	CUTTING, STABBING, PUNCTURING	MEDIUM	Isolate power to machine prior to any checks or maintenance. Do not open or clean inside until the machine has completely stopped. Keep hands clear of all blades and moving parts. Use a push stick where necessary. Care must be taken when handling knives. Make sure all guards are secured shut when machine is on.
D	SHEARING	MEDIUM	Make sure all guards are secured shut when machine is on.
F	STRIKING	MEDIUM	Do not stand behind timber when feeding into machine. A face mask must be worn at all times. Ensure to use correct feed rates for material.
H	ELECTRICAL	MEDIUM	All electrical enclosures should only be opened with a tool that is not to be kept with the machine. Machine should be installed & checked by a Licensed Electrician.
O	OTHER HAZARDS, NOISE, DUST.	LOW	Wear hearing protection as required. Must be connected to dust extraction
Plant Safety Program to be read in conjunction with manufactures instructions			



"THE JUNCTION" 2 WINDSOR ROAD, NORTHMEAD NSW 2152
Phone (02) 9890 9111 Fax (02) 9890 3888

Authorised and signed by: 
 Safety officer:
 Manager:
 Date: Mar-02